

SUBJECT: Shoulder harness attachment

APPLICATION: All Glasair II, II-S, and IIIs with rear windows installed.

DESCRIPTION: Testing has been conducted to determine the integrity of the shoulder harness attach point described for an aircraft that has rear windows installed, in our manuals prior to revisions dated 1/01/93 and later. Based on our analysis and actual pull tests using a tensile test machine, the original shoulder harness attach web would meet the FAR requirements. However, because they are not fabricated in a controlled production environment the bond integrity can vary from one installation to another. The new design significantly exceeds the requirement and provides a better margin for builder variances.

Because of the type of injuries that could result, the importance of this modification warrants the mandatory nature of this bulletin.

SOLUTION: Using the following instructions, relocate the shoulder harness attach points to improve their integrity.

SHOULDER HARNESS INSTALLATION

The shoulder harnesses are attached to laminated flanges formed on the upper inside surface of each fuselage half, as shown in FIGURES (1) and (2).

Remove the original shoulder harness attach flange measuring about 3" long (if installed) by cutting off the flange with a small fine tooth saw. Carefully remove the remaining laminate pad with a small disc sander. Use caution to not damage the original inner fuselage laminates.

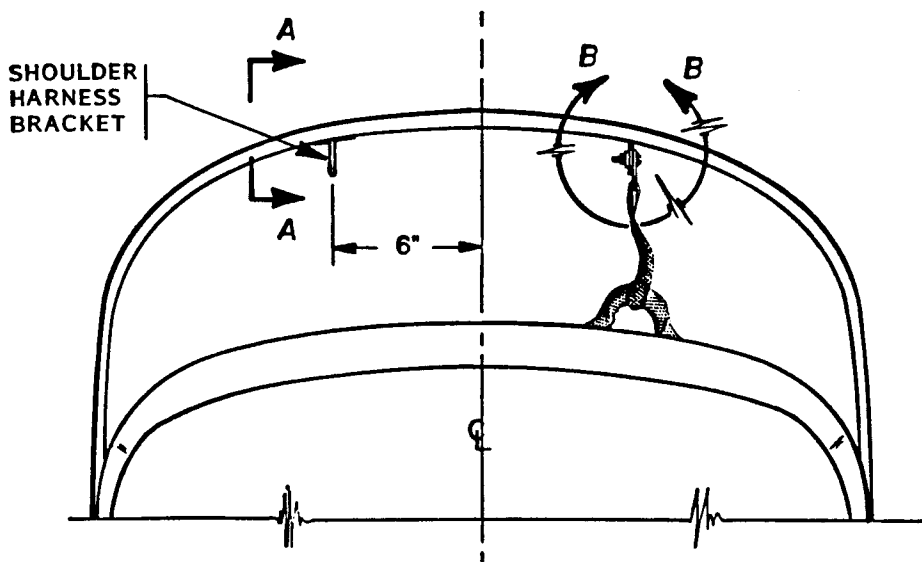

FIGURE (1)

VIEW LOOKING AFT



MODEL GLASAIR	ASSEMBLY NAME SERVICE BULLETIN 120	REVISION	DATE 11/18/93	VOLUME	PAGE 1 of 3
------------------	---------------------------------------	----------	------------------	--------	----------------

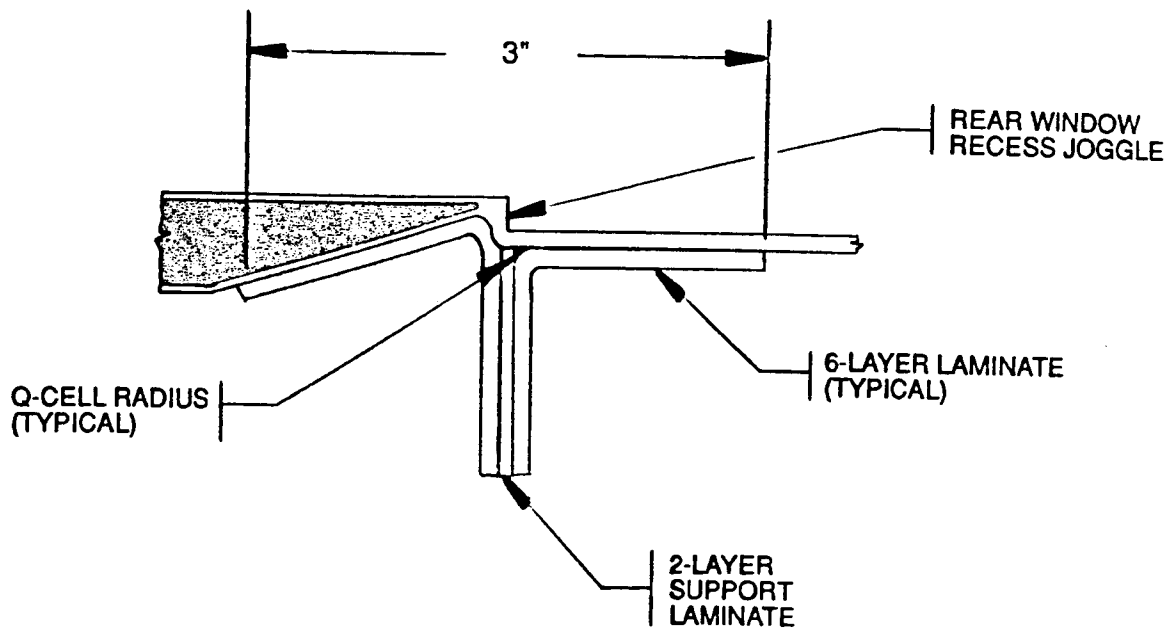
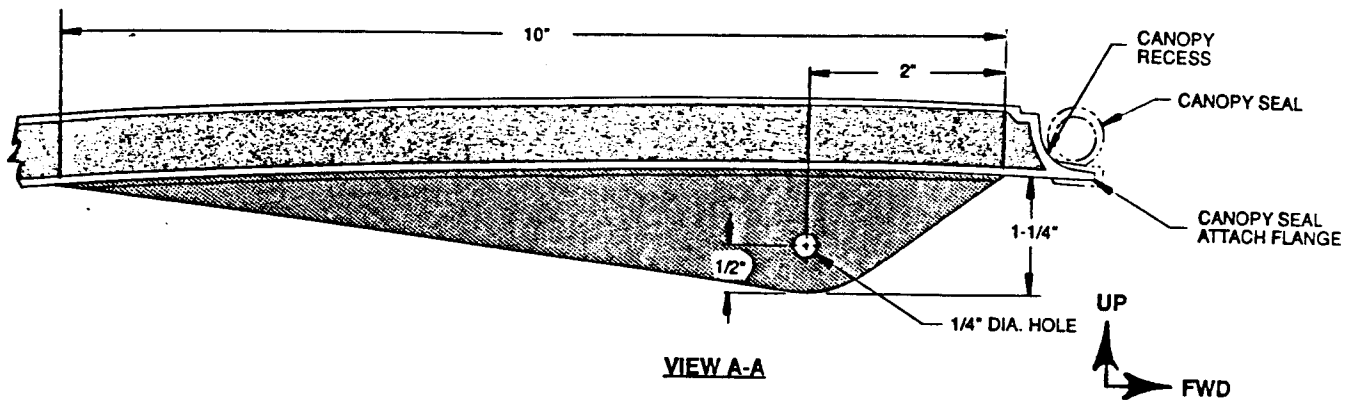

FIGURE (2)

STODDARD-HAMILTON
 AIRCRAFT, INCORPORATED

MODEL	ASSEMBLY NAME	REVISION	DATE	VOLUME	PAGE
GLASAIR	SERVICE BULLETIN 120		11/18/93		2 of 3

WARNING: Studies have shown that shoulder harnesses that mount to the seat back level with or below the shoulder can crush the spine in the event of a crash. Shoulder harnesses that mount above the shoulder, as described here, prevent this sort of injury from occurring.

Cut two 1-1/4" x 10" pieces from a two-layer precured laminate. Taper the ends and contour the mating edges of the support laminates so that they fit flush to the inside of the fuselage, as shown in FIGURE (2), View A-A. Sand the shiny surfaces of the support laminate with rough grit sandpaper until dull to prepare a good surface for laminating.

Position each upper harness attach support laminate on the inside of the fuselage 6" from the fuselage centerline aft of the canopy openings, as shown in FIGURES (1) and (2). Bond the support laminates in place with dabs of hot glue and radius the corners with a Q-cell/resin mixture, as shown in FIGURE (2), View B-B.

NOTE: The 6" dimension will position the shoulder harness support laminates close to the inboard edges of the molded recess for the rear windows.

Cut (24) 3" x 10" pieces of bidirectional cloth on the 45° bias and lay up six layers of cloth on each side of each support laminate. Trim the cloth flush to the support laminates in the green cure state, if possible. If not, file or sand the laminates flush after curing, as shown in FIGURE (2), View A-A.

NOTE: If the kit is still under construction and the opening for the rear windows has not yet been cut out, the new shoulder harness bracket laminates will be partially cut away on the outboard sides of the brackets as windows are installed. This is normal and acceptable.

Drill a 1/4" diameter hole in each of the attach laminates for attaching the shoulder harnesses. Use the AN4-6A bolts, AN970-4 washers, NAS77-4-15 bushings, and the AN364-428A nuts, supplied with the aircraft kit, to fasten the shoulder harnesses to the attach laminates and assemble per the kit construction manual.

 STODDARD-HAMILTON AIRCRAFT, INCORPORATED				
MODEL	ASSEMBLY NAME	REVISION	DATE	PAGE
GLASAIR	SERVICE BULLETIN 120		11/18/93	3 of 3