

SERVICE BULLETIN 146 — MANDATORY

SUBJECT: Glasair II-S FT and Super II FT Nose Gear Trunnion Attach Plate Fasteners

APPLICABILITY: All Glasair II-S FT and Super II FT aircraft

DISCUSSION: A recent incident in which a Glasair II-S FT landed short of the runway brought our attention to an area of the nose gear trunnion attachment that we feel could be strengthened, particularly for aircraft with larger, non-standard engines. This additional strength will provide greater nose gear durability for unusual landing or taxiing conditions that might impose loads in excess of those encountered in normal operations. This bulletin requires that the size of the fasteners through the nose gear trunnion attach plates be increased from 3/16" to 1/4" diameter and that the number of the fasteners for each plate be increased from four to six on all existing II-S FT and Super II FT aircraft.

NOTE: Refer to Subsection K in the Fuselage Assembly section of your *Instruction Manual* for a description of the nose gear hardware installation.

REQUIRED ACTION: One-by-one, remove each of the AN3-14A bolts that secure the nose gear trunnion attach plates to the nose gear support ribs. With the attach plate still secured to the support rib by the other bolts and using the original bolt hole as a guide, drill the empty hole up to 1/4"-diameter, being careful to drill square to the attach plate. Install an AN4-14A bolt in place of the original fastener. Secure the bolt with an AN364-428A nut with an AN960D416 washer against the attach plate and an AN970-4 washer against the support rib. Repeat for all four of the original bolts on each attach plate.

Then, as shown in Figure 1, locate and drill two additional 1/4" holes between the existing pairs of bolts. Install AN4-14A bolts; AN970-4 and AN960D416 washers; and AN364-428A nuts in these holes as described above.

If you have not yet mounted the attach plates, drill six 1/4"-diameter bolt holes through each attach plate and its support rib at initial assembly, and use the above-described hardware to secure the attach plates.

NOTE: It will be necessary to relieve the adjoining edges of each pair of AN970-4 large washers to prevent interference.



MODEL GLASAIR	ASSEMBLY NAME SERVICE BULLETIN 146	REVISION	DATE 9/5/96	VOLUME	PAGE 1 of 2
------------------	---------------------------------------	----------	----------------	--------	----------------

REQUIRED PARTS: Please contact the Stoddard-Hamilton Order Desk if you wish to order any of the following parts:

12 ea. AN4-14A bolt
12 ea. AN364-428A nut

12 ea. AN960D416 washer
12 ea. AN970-4 washer

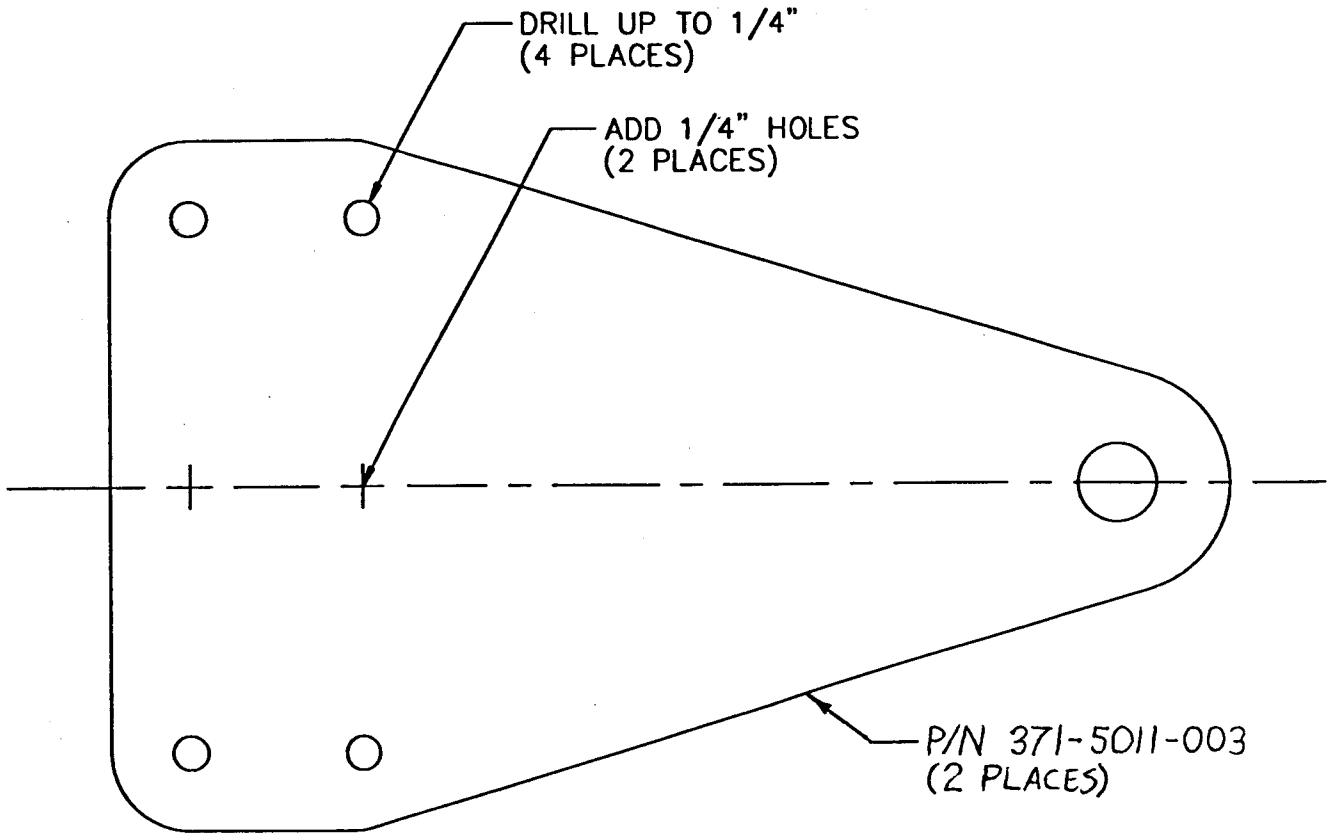

Figure 1: Modified Nose Gear Trunnion Attach Plate

STODDARD-HAMILTON
AIRCRAFT, INCORPORATED

MODEL GLASAIR	ASSEMBLY NAME SERVICE BULLETIN 146	REVISION	DATE 9/5/96	VOLUME	PAGE 2 of 2
------------------	---------------------------------------	----------	----------------	--------	----------------