

SERVICE BULLETIN 71

Subject: Horizontal Alignment Pin Nut

Applicability: Sportsman Pre-Built Horizontal and Two Weeks to Taxi Aircraft shipped between August 2012 and April 2014

Date: May 5, 2014

Discussion:

There may be some Pre-Built Horizontal Stabilizers that have AN315-6R Jam Nuts installed instead of AN365-624A Nuts.

Required Action:

Before your next flight, remove Horizontal Stabilizer and check the nut that holds the Horizontal Alignment Pin. If the nuts and washers are not AN365-624A Self-Locking Nuts and AN960D616 Washers, then contact the Glasair Aviation Parts Department at: parts@glasairaviation.com or 360-435-8533 X 221 and order the parts at no charge.

AN315-6R
(Incorrect Part)



AN365-624A
(Correct Part)



	Model	Document	Revision	Date	Page
	GlaStar / Sportsman	Service Bulletin 71	-	05-05-14	1 of 1

SECTION IV: HORIZONTAL STABILIZER ASSEMBLY



Note Be aware that the thickness of the stack-up you are riveting changes depending on whether you are riveting doubler and spar or doubler, spar and doubler. This situation will recur frequently throughout the riveting process; always alter your choice of rivet length accordingly.

Completed: []

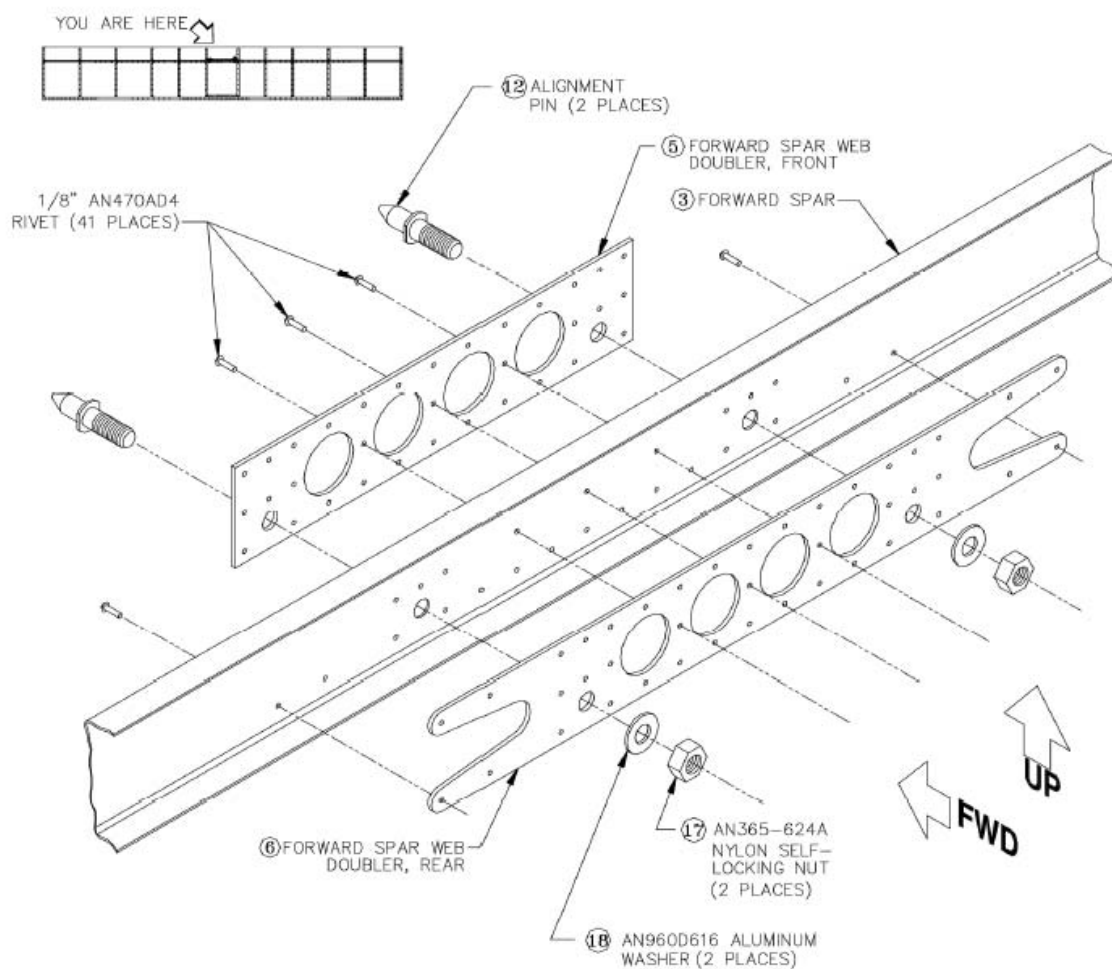

Figure 15: Riveting the Forward Spar Web Doublers

	Model	Document	Revision	Date	Page
	GlaStar / Sportsman	Service Bulletin 71	-	05-05-14	1 of 1