

GLASTAR SERVICE BULLETIN 47

Mandatory

Subject: Control Cable Safety Guides

Applicability: All GlaStar kits

Discussion: During flight on a customer's aircraft, the pilot initiated a series of banks using the ailerons to quickly reverse the roll. With the aircraft rolling one way and the ailerons quickly moved in the opposite direction, one aileron control cable jumped a pulley leaving the pilot in a dangerous situation with limited controllability of the aircraft. Fortunately he was able to land safely. Upon investigation, it was determined that the cable jumped the pulleys in the outboard pulley group in the wing even though the pulley had guides. For this reason, we are recommending all GlaStar kit owners inspect their complete control systems and make the following prescribed changes if your system is not per the following listed specifications.

The sole purpose of the cable guards is to keep the control cable retained on the pulley. All cable control systems have some inherent flexibility or stretch within the system and when one cable is loaded up with flight loads, the other cable will unload and can even go slack. It is on the slack cable that the guard will prevent the cable from falling off and becoming a dangerous situation.

Guards can be accomplished in several ways ranging from the use of cotter pins, clevis pins, bolts or other structure. The GlaStar uses several types depending on accessibility. Regardless of the type, the important point is that the clearance between the pulley and the guard never exceed the maximum limits. All the cables in the primary control system are 1/8 inch diameter flexible wire rope. In some cases the GlaStar Assembly Manual prescribes the maximum clearance limits between the edge of the guide and the outer diameter of the pulley to be a maximum 1/16 inch, in other places no limits were set. The new limits described herein, override all other limits discussed in the Assembly Manual.

The clearance between the guard and the side of the pulley also plays an important role. On page 175 in Section IX: Final Assembly, the Manual prescribes that the guides be manufactured 1-1/8 inches wide for double pulleys and 1/2 inch wide for single pulleys. Even if the maximum diameter clearance is kept very low (on the order of 1/64 inch) the thin fabricated guide could potentially still not be sufficient enough to keep a cable from jumping a pulley in an extreme condition.

Required Action: For this reason, all GlaStar control systems should be inspected and modified to conform to the following specifications as listed and shown in the following figures. If any cable guides fall outside of the prescribed limits, you should fabricate new guides per these figures. We recommend using material of thickness .025 inch for the fabrication of the new guides. If your existing guides, which were fabricated out of .020 inch material supplied under part number

	REVISION: -	DATE: 9/18/01	PAGE: 1 of 2
---	----------------	------------------	-----------------



600-00001-01, meet the prescribed tolerances there is no need to change over to the thicker material. Future kits will be supplied the thicker material under part number 600-00001-02.

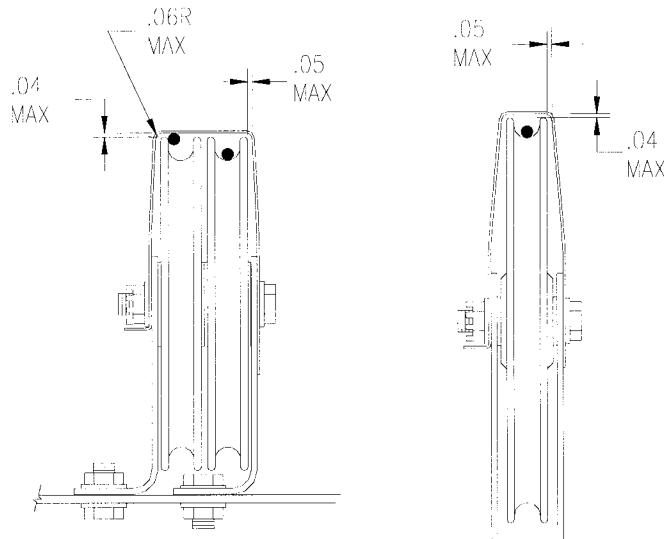

Figure 1: Cable guide clearance limits

As the figures show, the maximum clearance limits are the same for a single or double pulley group and are independent of the type of pulley used. Carefully measure the diameter and width of the pulleys as you fabricate each guide. Keep the corner bend radii tight like the figures show. Large internal bend radii make it difficult to meet the maximum limits. These bend radii are below the recommended material bend limits, but in this non-structural application it does not pose a problem. You will find by using a hard plastic or rubber hammer and forming the material over a block of wood or vice-jaw, a close tolerance guide can easily be achieved. We recommend using pieces of wood that are 0.96 inches thick and 0.48 inches thick for double and single pulley guides respectively. Be careful when drilling the holes for the pulley bolt, starting off with an undersized pilot hole and then drilling it up to final size. Check your final clearance gaps with a small piece of shim stock. Remember these are maximum limits, your final clearances will be less.

All other control system pulleys and cable guards should be inspected. Where cotter or clevis pins are used, the 1/16" maximum clearance limits between the pulley outside diameter are acceptable because the clevis pins and brackets are far more rigid than the thin fabricated guides. If your pins do not meet the 1/16" maximum allowed limit, simply re-drill the hole in a new location or manufacture a thin walled sleeve to go over the clevis or cotter pin to meet the prescribe limits. If your pulleys are too far away from a welded bracket guide (lower outboard flap pulleys) you can simply rivet a thin shim from any suitable material onto the bracket to meet the allowable clearances.

	REVISION: -	DATE: 9/18/01	PAGE: 2 of 2
--	----------------	------------------	-----------------